

# 4-port USB3.0 HUB Controller Chip CH634

Datasheet 1

Version: V1.7

<https://wch-ic.com>

## 1. Overview

CH634 is a 4-port USB ultra-high-speed HUB controller chip conforming to the USB3.2 Gen1 protocol specification, and the single chip integrates the functions of 4-port USB HUB and USB PD. CH634 has independent SS HUB controller and USB2.0 HUB controller, and has built-in 5 sets of SS PHY, 5 sets of USB2.0 PHY and 2 sets of PD PHY. The upstream port of CH634 chip supports USB3.0 ultra-high speed 5Gbps, USB2.0 high-speed 480Mbps and full-speed 12Mbps, and the downstream port supports USB3.0 ultra-high-speed, USB2.0 high-speed, full-speed and low-speed 1.5Mbps.

CH634X has 2 built-in Type-C dual-channel USB3.0 PHYs and dual PD PHYs, compatible with USB-C cables and connection specifications, native support for Type-C forward and reverse plugging adaptive, native support for PDHUB, Type-C power 15W and PD 100W fast charging (20V\*5A).

CH634 supports high-performance concurrent processing MTT mode, adopts industrial-grade design, and the periphery is simplified, which can be applied to computer and industrial computer motherboards, docking stations, peripherals, embedded systems and other scenarios.

The following figure shows the system block diagram of CH634.

Figure 1-1 System block diagram

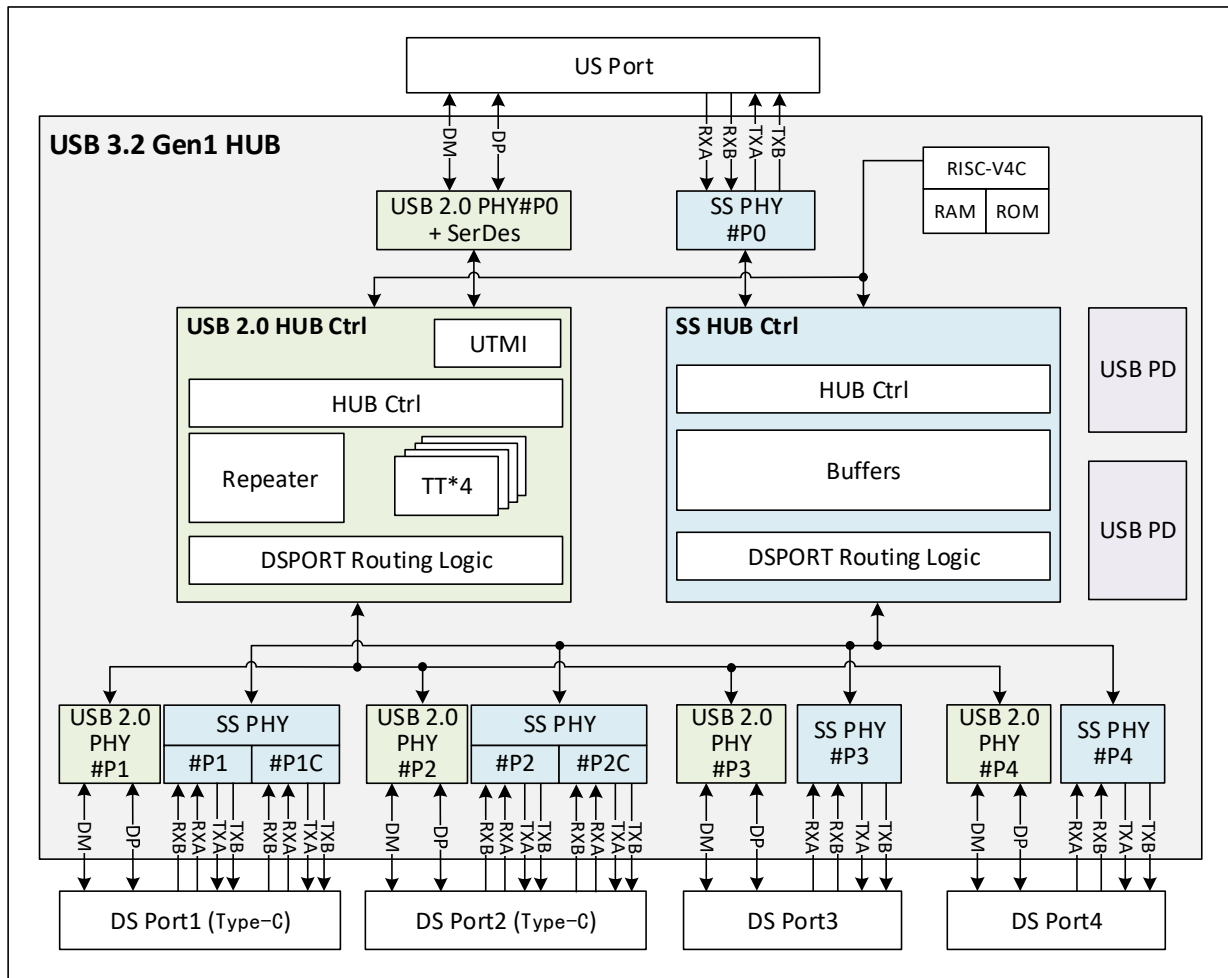

## 2. Feature

- 4-port USB3.2 Gen1 HUB, providing 4 downstream ports, supporting USB3.2 Gen1(5Gbps), and accommodating USB3.1, USB3.0, USB2.1, USB2.0, USB1.1 and USB1.0 forward.
- USB3.2 Gen1 HUB module supports U0/U1/U2/U3 power management mode conforming to USB 3.2gen1 protocol specification.
- Some models have built-in 2 sets of self-developed Type-C dual-channel USB3.0 PHY, which native support for Type-C forward and backward insertion adaptive.
- USB2.0 HUB module supports L0/L1/L2/L3 power management mode conforming to USB2.1 protocol specification.
- Support low-cost STT or high-performance MTT mode, and MTT configures independent TT for each port to realize high-speed transmission.
- Built-in 2 USB PD PHY, native support for Type-C power 15W and PD 100W fast charging, support for PDHUB and docking station.
- Downstream supports BC1.2 charging protocol and CDP.
- Compatible with USB Type-C cable and connection specification, 3 C-port working modes, and support for downstream double C-port or upstream C-port.
- Support GANG integrated linkage power supply control and GANG integrated overcurrent detection
- Some models support independent power control of each port and independent overcurrent detection of each

port.

- Self-developed USBPHY for HUB, low-power technology, supporting self-power supply or bus power supply.
- Some models support SMBus bus and support motherboard integration and management.
- CH634M, CH634X, CH634W6C and CH634W8G support upstream port exchange function, which is convenient for 2 USB hosts to manage multiple USB devices.
- Support independent or integral control, power supply mode and other functions through I/O pin configuration
- The external EEPROM, external FLASH or internal EEPROM can be used to configure whether the HUB chip supports composite devices, non-removable devices, custom VID, PID, port configuration, USB vendor, product, serial number string descriptor, etc.
- Built-in information memory, which can customize the information and configuration of manufacturers or products in lots according to the special needs of the industry
- It integrates a 3.3V LDO voltage regulator and a 1.2V DC-DC buck, supports external 5V power supply, and simplifies the periphery.
- Some models support adding Type-C interface chip CH211 to realize 28V high-voltage PDHUB and docking station.
- QingKe RISC-V processor core, controllers such as SuperSpeed USB, high-speed USB and USBPD, and the IP of the physical layer transceiver are all self-researched, and all modules are closely coordinated, with high efficiency and low cost, and the IP licensing fee is exempted.
- Provide QFN32, QFN48, QFN64, QFN68 and other packaging forms.

Table 2-1 Function comparison of models in the same cluster

Model Function	F	M	X	W5M	W6C	W6G	W6T	W7G	W7R	W7S	W7U	W7V	W8G
USB2 port	4	4	4	4	4	4	4	4	4	4	4	4	4
USB3 port	2	4	4+2C	4	4	4	4	4	4	4	4	4	4+2C
PD controller	×	1	2	×	×	1	×	×	×	×	×	×	2
Upstream exchange	×	√	√	×	√	×	×	×	×	×	×	×	√
MTT mode	√	√	√	√	√	√	√	√	√	√	√	√	√
Independent overcurrent detection	×	×	4	4	4	×	4	4	4	4	2	4	4
Overall overcurrent detection	√	√	√	√	√	√	√	√	√	√	√	√	√
Independent power control	×	×	4	4	1	×	4	4	4	4	2	4	4
Overall power control	√	√	√	√	√	√	√	√	√	√	√	√	√
I/O Configuration	-	-	√	√	√	-	√	√	-	√	-	-	√
Overall/													

Independent													
I/O configuration power control polarity	-	-	-	-	-	√	√	-	-	-	-	√	-
LED	×	1	1	×	1	1	4	4+4+1	4+4	4	4+4+1	4	4+1
Internal EEPROM configuration	√	√	√	√	√	√	√	√	√	√	√	√	√
External EEPROM configuration	×	×	×	×	×	×	√	×	√	×	×	×	×
External FLASH configuration	×	×	×	√	√	√	×	√	√	√	√	√	√
SMBus interface configuration	√	√	√	√	√	×	√	√	√	×	√	√	√
Customized configuration	√	√	√	√	√	√	√	√	√	√	√	√	√
I/O configuration BC charging	-	√	-	√	√	√	-	√	√	√	√	√	√
Type-C fast charging 15W	×	√	√	×	×	√	×	×	×	×	×	×	√
PDHUB fast charging 100W	×	√	√	×	×	√	×	×	×	×	×	×	√
Single 5V supply	×	√	√	×	√	√	×	√	√	√	√	√	√
Single 3.3V supply	×	√	√	×	√	√	×	√	√	√	√	√	√
3.3V+1.2V dual power supply	√	√	√	√	√	√	√	√	√	√	√	√	√
Package pin count	32	48	68	56	64	64	64	76	76	76	76	76	88
Body size	4*4	5*5	8*8	7*7	8*8	8*8	9*9	9*9	9*9	9*9	9*9	9*9	10*10

Note: For the 3 functions in the table Integral/Independent, Power Control Polarity, and BC Charging, “-” indicates that EEPROM or FLASH configuration is supported, and “√” indicates that I/O configuration is also supported.

### 3. Pinouts

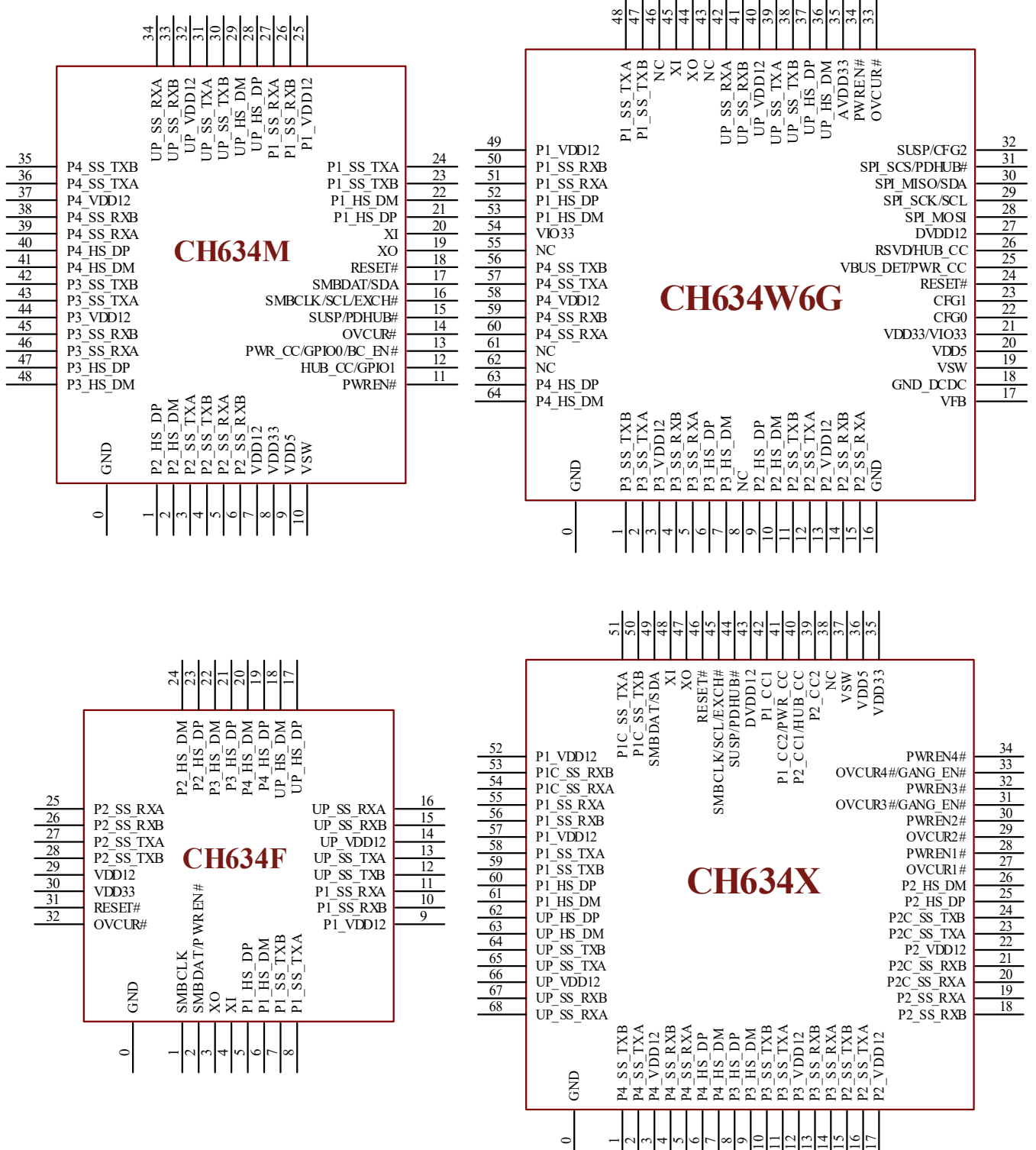

Package Form	Body Size	Pin Pitch	Package Description	Order Model	
QFN32	4*4mm	0.4mm	15.7mil	Quad Flat No-Lead Package	CH634F
QFN48	5*5mm	0.35mm	13.8mil	Quad Flat No-Lead Package	CH634M

QFN68	8*8mm	0.4mm	15.7mil	Quad Flat No-Lead Package	CH634X
QFN64	8*8mm	0.4mm	15.7mil	Quad Flat No-Lead Package	CH634W6G

Note: 1. Pin 0# is the EPAD of QFN package and is a necessary connection.

2. CH634F, CH634W5M and CH634W6T have no LDO voltage regulator and DC-DC step-down, and need external power supply of 3.3V and 1.2V at the same time. Other models have built-in 3.3V LDO voltage regulator and 1.2V DC-DC buck, and external single power supply is 5V or 3.3V.

3. The 4 downstream ports of CH634F include 2 USB3.2 Gen1 and 2 USB2.0; Other models include 4 USB3.2 Gen1 downstream ports and 4 USB2.0; Among them, CH634X and CH634W8G contain 2 sets of native Type-C/PD forward and backward insertion adaptive ports.

4. Custom pins CH634W5M, CH634W6C, CH634W6T, CH634W7G, CH634W7R, CH634W7S, CH634W7U, CH634W7V and CH634W8G are only reserved in lots. For the pin arrangement, pin definition and package information, please refer to the CH634DS2 manual.

## 4. Pin Definitions

Table 4-1 USB signal related pin function description

USB signal pin	Pin name	Type <sup>(1)</sup>	Function description
Upstream port USBSS differential signal	UP_SS_TXA UP_SS_TXB	USB3	Upstream port USBSS differential transmission signal line TX+/TX- or TX-/TX+ (automatic cross identification).
	UP_SS_RXA UP_SS_RXB	USB3	Upstream port USBSS differential receiving signal line RX+/RX- or RX-/RX+ (automatic cross identification).
Upstream port USB2.0 differential signal	UP_HS_DP	USB2	Upstream port USB2.0 differential signal D+.
	UP_HS_DM	USB2	Upstream port USB2.0 differential signal D-.
1#downstream port USBSS differential signal	P1_SS_TXA P1_SS_TXB	USB3	1#Downstream port USBSS differential transmission signal line TX+/TX- or TX-/TX+ (automatic cross identification).
	P1_SS_RXA P1_SS_RXB	USB3	1# Downstream port USBSS differential receiving signal line RX+/RX- or RX-/RX+ (automatic cross identification).
1# downstream port USB2.0 differential signal	P1_HS_DP	USB2	1# Downstream port USB2.0 differential signal D+.
	P1_HS_DM	USB2	1# Downstream port USB2.0 differential signal D-.
2# downstream port USBSS differential signal	P2_SS_TXA P2_SS_TXB	USB3	2# Downstream port USBSS differential transmission signal line TX+/TX- or TX-/TX+ (automatic cross identification).
	P2_SS_RXA P2_SS_RXB	USB3	2# Downstream port USBSS differential receiving signal line RX+/RX- or RX-/RX+ (automatic cross identification).
2# downstream port USB2.0 differential signal	P2_HS_DP	USB2	2# Downstream port USB2.0 differential signal D+.
	P2_HS_DM	USB2	2# Downstream port USB2.0 differential signal D-.
3# downstream port USBSS differential signal	P3_SS_TXA P3_SS_TXB	USB3	3# Downstream port USBSS differential transmission signal line TX+/TX- or TX-/TX+ (automatic cross identification).
	P3_SS_RXA P3_SS_RXB	USB3	3# Downstream port USBSS differential receiving signal line RX+/RX- or RX-/RX+ (automatic cross identification).
3# downstream port USB2.0 differential signal	P3_HS_DP	USB2	3# Downstream port USB2.0 differential signal line D+.
	P3_HS_DM	USB2	3# Downstream port USB2.0 differential signal line D-.
4# downstream port USBSS differential signal	P4_SS_TXA P4_SS_TXB	USB3	4# Downstream port USBSS differential transmission signal line TX+/TX- or TX-/TX+ (automatic cross identification).
	P4_SS_RXA P4_SS_RXB	USB3	4# Downstream port USBSS differential receiving signal line RX+/RX- or RX-/RX+(automatic cross

			identification).
4# downstream port USB2.0 differential signal	P4_HS_DP	USB2	4# Downstream port USB2.0 differential signal line D+.
	P4_HS_DM	USB2	4# Downstream port USB2.0 differential signal line D-.
1# or 2# downstream port Type-C differential signal	PxC_SS_TXA PxC_SS_TXB	USB3	1# or 2# Downstream port Type-C differential signal line TX+/TX- or TX-/TX+ (automatic cross identification).
	PxC_SS_RXA PxC_SS_RXB	USB3	1# or 2# Downstream port Type-C differential signal line RX+/RX- or RX-/RX+ (automatic cross identification).

Table 4-2 CH634F and CH634M pin definitions

Pin No. (Pin with the same name can be referenced)		Pin name	Type <sup>(1)</sup>	Function description
CH634F	CH634M			
-	9	VDD5	P	5V power input, it is recommended to connect 0.1uF parallel 10uF decoupling capacitor. If the voltage of VDD5 is less than 3.6V, it should be shorted to VDD33.
-	10	VSW	P	DCDC output, need to be close to the pin series inductor to generate 1.2V power supply, and 1.2V power supply needs to be placed close to the ground capacitance, it is recommended to use a 2.2uH inductor and at least one 10uF capacitor.
-	8	VDD33	P	3.3V LDO output terminal, analog power supply and I/O pin power supply input, it is recommended to connect 0.1uF parallel 10uF decoupling capacitor.
30	-	VDD33	P	Analog power supply and I/O pin power supply input, it is recommended to connect 0.1uF parallel 10uF decoupling capacitor.
29	7	VDD12	P	1.2V core power supply and 1.2V power supply input of 2# downstream port, it is proposed to connect 0.1uF or 1uF decoupling capacitor externally.
0	0	GND	P	Common ground terminal, must be connected to GND.
14	32	UP_VDD12	P	Upstream port 1.2V power input, external 0.1uF decoupling capacitor
9	25	P1_VDD12	P	1#Downstream port 1.2V power input, external 0.1uF decoupling capacitor
-	44	P3_VDD12	P	3#Downstream port 1.2V power input, external 0.1uF decoupling capacitor
-	37	P4_VDD12	P	4# Downstream port 1.2V power input, external 0.1uF decoupling capacitor



4	20	XI	I	The input terminal of crystal oscillator is connected with one terminal of external 24MHz crystal and capacitor to ground.
3	19	XO	O	The inverted output terminal of the crystal oscillator is connected to the other terminal of the external 24MHz crystal and the capacitor to ground.
13/12/16/15	31/30/34/33	UP_SS_XXX	USB3	Upstream port USBSS differential transmit or receive signal line.
17/18	28/29	UP_HS_XX	USB2	Upstream port USB2.0 differential signal line.
8/7/11/10	24/23/27/26	P1_SS_XXX	USB3	1#Downstream port USBSS differential transmit or receive signal line.
5/6	21/22	P1_HS_XX	USB2	1#Downstream port USB2.0 differential signal line.
26/25/28/27	3/4/5/6	P2_SS_XXX	USB3	2#Downstream port USBSS differential transmit or receive signal line.
23/24	1/2	P2_HS_XX	USB2	2#Downstream port USB2.0 differential signal line.
-	43/42/46/45	P3_SS_XXX	USB3	3#Downstream port USBSS differential transmit or receive signal line.
21/22	47/48	P3_HS_XX	USB2	3#Downstream port USB2.0 differential signal line.
-	36/35/39/38	P4_SS_XXX	USB3	4#Downstream port USBSS differential transmit or receive signal line.
19/20	40/41	P4_HS_XX	USB2	4#Downstream port USB2.0 differential signal line.
32	14	OVCUR#	I	Overall mode downstream port overcurrent detection input pin, low level overcurrent, built-in pull-up.
2	-	SMBDAT	I/O	SMBus bus data signal line.
		PWREN#	O	Overall mode downstream port power output control pin, low on.
1	-	SMBCLK	I	SMBus clock signal line. As a configuration pin during reset, it is used to configure the SMBDAT/PWREN# pin function of CH634F chip. If an external pull-up resistor (such as 10K resistor) is detected, it is configured as SMBDAT function, otherwise it is configured as PWREN# function.
31	18	RESET#	I	External reset input, built-in pull-up resistor, active low level, can be suspended when not in use, it is recommended to short-circuit VDD33 to prevent interference.
-	17	SMBDAT	I/O	General HUB mode: SMBus data signal line.
			I	As a configuration pin during reset to enable or disable the SMBus interface, disabling SMBus if externally grounded, enabling the upstream port switching function, and configuring the SMBCLK pin for EXCH# functionality, otherwise enabling the SMBus

				interface.
		SDA	I/O	PD-HUB mode: Data signal line of 2-wire serial interface, used to connect CH211 chip.
-	16	SMBCLK	I	Turn off the general HUB mode of SMBus: SMBus clock signal line.
		SCL	O	PD-HUB mode: clock signal line of 2-wire serial interface, used to connect CH211 chip.
		EXCH#	I	Turn off the general HUB mode of SMBus: This pin is the upstream port and 1# downstream port switching control input pin, suspend or pull-up does not switch, input low level control switching.
-	11	PWREN#	O	Overall mode downstream port power output control pin, turned on at low level.
-	15	SUSP	O	Sleep state output pin, which can be used to drive LED. The output level is the same as the default state of the pull-up and pull-down resistor configuration during sleep, but the output level is opposite during normal operation.
		PDHUB#	I	During reset, it is used as a configuration pin to configure general HUB mode or PD-HUB mode, with built-in pull-up resistor, which is configured as general HUB mode in floating or high level, and is configured as PD-HUB mode in low level with additional pull-down resistor.
-	13	PWR_CC	I/O	PD-HUB mode: the external power supply terminal PD protocol communication pin is used to connect the Type-C power adapter.
		GPIO0	I/O	General GPIO0, used for I/O port input or output.
		BC_EN#	I	General HUB mode: used as a configuration pin during reset to configure whether BC charging function is enabled or not. Built-in pull-up resistor is used to prohibit BC charging when it is suspended or high, and low-level pull-down resistor is used to enable BC charging.
-	12	HUB_CC	I/O	PD-HUB mode: the communication pin of upstream PD protocol is used to connect USB hosts such as mobile phones/computers.
		GPIO1	I/O	General GPIO1, used for I/O port input or output.

Table 4-3 CH634W6G pin definitions

Pin No. (Pin with the same name can be referenced)	Pin name	Type <sup>(1)</sup>	Function description
--	----------	---------------------	----------------------

20	VDD5	P	For the DCDC power input, it is recommended to connect an external 10uF capacitor to ground.
			The 5V power supply input of 3.3V LDO is recommended to be externally connected with 1uF capacitor. If the voltage of VDD5 is less than 3.6V, it should be shorted to VDD33.
19	VSW	P	At the DCDC output end, an inductor needs to be connected in series close to the pin to generate a 1.2V power supply, and the 1.2V power supply needs to be placed close to a ground capacitor. It is recommended to use a 2.2uH inductor and at least one 10uF capacitor.
17	VFB	P	For the voltage feedback end of DCDC, it is recommended to connect 0.1uF capacitor to ground and directly connect the DC-DC output 1.2V power supply.
21	VDD33/ VIO33	P	3.3V LDO output and IO pin power input, it is recommended to connect 0.1uF parallel 10uF or 4.7uF decoupling capacitor.
35	AVDD33	P	3.3V analog power input, it is recommended to connect 0.1uF parallel 10uF or 4.7uF decoupling capacitor.
27	DVDD12	P	1.2V core power input, it is recommended to connect 0.1uF or 1uF decoupling capacitor externally.
54	VIO33	P	IO pin power supply input, external supply of 3.3V, it is recommended to externally connect 1uF or 0.1uF decoupling capacitor.
18	GND_DCD C	P	DCDC ground terminal, must be connected to GND.
0	GND	P	Common ground terminal, must be connected to GND.
16	GND	P	Optional ground terminal, recommended to connect to GND.
40	UP_VDD12	P	Upstream port 1.2V power input, external 0.1uF decoupling capacitor.
49/13/3/58	Px_VDD12	P	1-4# downstream port has 1.2V power input, and is externally connected with 0.1uF decoupling capacitor.
45	XI	I	The input end of the crystal oscillator is connected with one end of the external 24MHz crystal and the capacitance to the ground.
44	XO	O	The invert output end of that crystal oscillator is connected with the other end of the external 24MHz crystal and the capacitance to the ground.
39/38/42/41	UP_SS_XXX	USB3	Upstream port USBSS differential sending or receiving signal line.
37/36	UP_HS_XX	USB2	Upstream port USB2.0 differential signal line.
48/47/51/50	P1_SS_XXX	USB3	1# Downstream port USBSS differential transmit or receive signal line.
52/53	P1_HS_XX	USB2	1# Downstream port USB2.0 differential signal line.

12/11/15/14	P2_SS_XXX	USB3	2# Downstream port USBSS differential transmit or receive signal line.
9/10	P2_HS_XX	USB2	2# Downstream port USB2.0 differential signal line.
2/1/5/4	P3_SS_XXX	USB3	3# Downstream port USBSS differential transmit or receive signal line.
6/7	P3_HS_XX	USB2	3# Downstream port USB2.0 differential signal line.
57/56/60/59	P4_SS_XXX	USB3	4# Downstream port USBSS differential transmit or receive signal line.
63/64	P4_HS_XX	USB2	4# Downstream port USB2.0 differential signal line.
33	OVCUR#	I	1# Downstream port overcurrent detection input pin, low level overcurrent; Downstream port overcurrent detection input pin in overall mode, overcurrent at low level.
34	PWREN#	O	1# Downstream port power output control pin, low level on; Downstream port power output control pin in overall mode, low level on.
		I	During reset, it is used as a configuration pin to configure the output polarity of the power control pin. The built-in pull-up resistor is, and the PWREN pin is active when the output is low or high. If the pull-down resistor is low, the PWREN pin is active when the output is low. The pin is active in the output high level.
24	RESET#	I	External reset input, built-in pull-up resistor, low level is valid, can be left floating when not in use, it is recommended to short-circuit VDD33 to prevent interference.
28	SPI_MOSI	O	Data output of SPI interface.
31	SPI_SCS	O	General HUB mode: CS output of SPI interface.
		I	During reset, it is used as a configuration pin for configuring general HUB mode or PD-HUB mode, built-in pull-up resistor, floating or high-level configuration in general HUB mode, and additional pull-down resistors are placed on low level configuration in PD-HUB mode.
29	SPI_SCK	O	General HUB mode: Clock output of SPI interface.
	SCL	O	PD-HUB mode: Clock signal line of the 2-wire serial interface is used to connect the CH211 chip.
30	SPI_MISO	I	General HUB mode: Data input of SPI interface, built-in pull-up resistor.
	SDA	I/O	PD-HUB mode: Data signal line of 2-wire serial interface with built-in pull-up resistor, used to connect CH211 chip.
25	VBUS_DET	I	General HUB mode: USB bus VBUS status detection input.

			The VBUS power supply should be connected to this pin after being divided by two resistors. When this function is not used, this pin needs to be short-circuited with VIO33.
	PWR_CC	I/O	PD-HUB mode: PD protocol communication pin on the external power supply end, used to connect a Type-C power adapter.
26	RSVD	I	General HUB mode: Reserved, built-in pull-up resistor, recommended to leave it floating.
	HUB_CC	I/O	PD-HUB mode: Upstream PD protocol communication pin, used to connect to USB hosts such as mobile phones/computers.
32	LED	O	The LED sleep state output pin, the output level during sleep is the same as the default state of the up-and-pull-down resistor configuration, and the output level during normal operation is the opposite.
	CFG2	I	During reset, it is used as a configuration pin to configure whether to enable BC charging function. Built-in pull-up resistor is, the floating or high level is to enable BC charging, and the pull-down resistor is to set the low level to prohibit BC charging.
23	CFG1	I	4# Downstream port function configuration; During reset, as a configuration pin, if the pull-down resistor is placed at a low level, the downstream port 4# is disabled; if the downstream port 4# is placed at a low level, the downstream port 4# is placed at a low level. If the pull-down resistor is placed at a high level, the pin is configured at a 4# is placed at a low level. #Downstream port overcurrent indicator.
22	CFG0	I	3# Downstream port function configuration; During reset, as a configuration pin, if the downstream port 3# is suspended, the downstream port 3# is not removable. If the pull resistor is placed at a high level, the pin is configured as the overcurrent indicator of the downstream port 3# is suspended.
8/43/46/55/61/62	NC	-	Reserved, suggested suspension

Table 4-4 CH634X pin definitions

Pin No. (Pin with the same name can be referenced)	Pin name	Type <sup>(1)</sup>	Function description
36	VDD5	P	The 5V power supply input of 3.3V LDO is recommended to be externally connected with 1uF capacitor. If the voltage of VDD5 is less than 3.6V, it should be shorted to VDD33.
37	VSW	P	At the output end of DCDC, an inductor needs to be

			connected in series close to the pin to generate a 1.2V power supply, and the 1.2V power supply needs to be placed with a ground capacitor nearby. It is recommended to use a 2.2uH inductor and at least one 10uF capacitor.
35	VDD33	P	3.3V LDO output terminal, it is recommended to externally connect 1uF~10uF capacitance to ground.
43	DVDD12	P	1.2V core power input, it is recommended to connect 0.1uF or 1uF decoupling capacitor externally.
0	GND	P	The common ground terminal must be connected to GND.
66	UP_VDD12	P	Upstream port 1.2V power supply input, external 0.1uF decoupling capacitor.
57(52)/17(22)/12/3	Px_VDD12	P	1-4# downstream port has 1.2V power input, and is externally connected with 0.1uF decoupling capacitor.
48	XI	I	The input end of the crystal oscillator is connected to one end of the external 24MHz crystal and the ground capacitor.
47	XO	O	The inverted output terminal of the crystal oscillator is connected to the other end of the external 24MHz crystal and the ground capacitor.
65/64/68/67	UP_SS_XXX	USB3	Upstream port USBSS differential transmit or receive signal line.
62/63	UP_HS_XX	USB2	Upstream port USB2.0 differential signal line.
58/59/55/56	P1_SS_XXX	USB3	1# Downstream port USBSS differential transmit or receive signal line.
51/50/54/53	P1C_SS_XXX	USB3	1# Downstream port Type-C differential transmit or receive signal line.
60/61	P1_HS_XX	USB2	1# Downstream port USB2.0 differential signal line.
16/15/19/18	P2_SS_XXX	USB3	2# Downstream port USBSS differential transmit or receive signal line.
23/24/20/21	P2C_SS_XXX	USB3	2# Downstream port Type-C differential transmit or receive signal line.
25/26	P2_HS_XX	USB2	2# Downstream port USB2.0 differential signal line.
11/10/14/13	P3_SS_XXX	USB3	3# Downstream port USBSS differential transmit or receive signal line.
8/9	P3_HS_XX	USB2	3# Downstream port USB2.0 differential signal line.
2/1/5/4	P4_SS_XXX	USB3	4# Downstream port USBSS differential transmit or receive signal line.
6/7	P4_HS_XX	USB2	4# Downstream port USB2.0 differential signal line.
28	PWREN1#	O	1# Downstream port power output control pin, low level on.
30	PWREN2#	O	2# Downstream port power output control pin, low level on.
32	PWREN3#	O	3# Downstream port power output control pin, low level on.
34	PWREN4#	O	4# Downstream port power output control pin, low level on.
27	OVCUR1#	I	1# Downstream port overcurrent detection input pin, low level overcurrent.
29	OVCUR2#	I	2# Downstream port overcurrent detection input pin, low

			level overcurrent.
31	OVCUR3#		3# Downstream port overcurrent detection input pin, low level overcurrent.
	GANG_EN#	I	During reset, it is used as a configuration pin for configuring the overall mode or independent mode. It has a built-in pull-up resistor. High level is independent mode. When it is detected that there is a pull-down resistor and OVCUR4# also detects that there is a pull-down resistor on the outside, it is an overall mode.
33	OVCUR4#		4# Downstream port overcurrent detection input pin, low level overcurrent.
	GANG_EN#	I	During reset, it is used as a configuration pin for configuring the overall mode or independent mode. It has a built-in pull-up resistor. High level is independent mode. When it is detected that there is a pull-down resistor and OVCUR3# also detects that there is a pull-down resistor on the outside, it is an overall mode.
44	SUSP	O	Sleep state output pin, which can be used to drive LED. The output level is the same as the default state of the pull-up and pull-down resistor configuration during sleep, but the output level is opposite during normal operation.
	PDHUB#	I	During reset, it is used as a configuration pin for configuring general HUB mode or PD-HUB mode, built-in pull-up resistor, floating or high-level configuration in general HUB mode, and additional pull-down resistors are placed on low level configuration in PD-HUB mode.
45	SMBCLK	I	Open the general HUB mode of SMBus: SMBus bus clock signal line.
	SCL	I/O	PD-HUB mode: the clock signal line of 2-wire serial interface is used to connect CH211 chip.
	EXCH#	I	Turn off SMBus general HUB mode: This pin is the upstream port and the downstream port 1# switch control input pin, floating or pull-up does not switch, input low level control switch.
46	RESET#	I	External reset input, built-in pull-up resistor, active low, can be suspended when not in use, it is recommended to short-circuit VDD33 to prevent interference.
49		I/O	General HUB mode: SMBus bus data signal line.
	SMBDAT	I	During reset, it is used as a configuration pin to enable or turn off the SMBus interface, if external ground is connected, SMBus is turned off, upstream switch function is enabled, and SMBCLK pin is configured as EXCH# function, otherwise the SMBus interface is enabled.
	SDA	I/O	PD-HUB mode: a data signal line of a 2-wire serial

			interface, used to connect to the CH211 chip.
42	P1_CC1	I/O (FT)	<p>General HUB mode: 1# downstream port PD protocol communication pin CC1. PD-HUB mode: 1# downstream port PD protocol communication pin CC1. In general HUB mode with SMBus off, if EXCH# is low, the pin switches to the PD protocol communication pin CC1 of the new upstream port as the downstream port of 1.</p> <p>If switched to the upstream port, this pin needs to be grounded via a 5.1K resistor. If P1_CC1 is grounded through a 5.1K resistor, the PIC_SS* signal is invalid and port 1# is changed from port C to port A.</p>
41	P1_CC2	I/O (FT)	<p>General HUB mode: 1# downstream port PD protocol communication pin CC2. In general HUB mode with SMBus off, if EXCH# is low, the pin switches to the PD protocol communication pin CC2 of the new upstream port as the downstream port of 1.</p> <p>If switched to the upstream port, this pin needs to be grounded via a 5.1K resistor. If P1_CC2 is grounded through a 5.1K resistor, the P1_SS* signal is invalid and port 1# is changed from port C to port A, and P1_SS* signal pin is optionally used.</p>
	PWR_CC	I/O	PD-HUB mode: the external power supply terminal PD protocol communication pin is used to connect the Type-C power adapter.
40	P2_CC1	I/O (FT)	General HUB mode: 2# downstream port PD protocol communication pin CC1. If P2_CC1 is grounded through a 5.1K resistor, the P2C_SS* signal is invalid, and the 2# port is changed from port C to port A.
	HUB_CC	I/O	PD-HUB mode: the communication pin of upstream PD protocol is used to connect USB hosts such as mobile phones/computers.
39	P2_CC2	I/O (FT)	<p>General HUB mode: 2# downstream port PD protocol communication pin CC2. If P2_CC2 is grounded through a 5.1K resistor, the P2_SS* signal is invalid, the 2# port is changed from port C to port A, and the P2C_SS* signal pin is selected.</p> <p>PD-HUB mode: 1# downstream port PD protocol communication pin CC2.</p>
38	NC	-	Reserved, suggested suspension.

Note 1: Pin type abbreviation explanation:

USB3 = USB3.0 signal pin;



*USB2 = USB2.0 signal pin;*

*I = Signal input;*

*O = Signal output;*

*P = Power or ground;*

*NC = Reserved;*

*FT = Tolerant 5V voltage.*

## 5. Function Description

### 5.1 Overcurrent Detection and Power Control

#### 5.1.1 Overcurrent Detection

Some CH634 models support 2 overcurrent protection modes: Independent overcurrent mode and overall overcurrent mode, while some models only support overall overcurrent mode, as shown in Table 5-1.

Table 5-1 Overcurrent protection control description

Chip model	Overcurrent configuration	Overcurrent mode	Overcurrent detection sampling pin	Reference figure
CH634F	-	Overall overcurrent	OVCUR#	Figure 5-2
CH634M	-	Overall overcurrent	OVCUR#	Figure 5-2
CH634W6G	-	Overall overcurrent	OVCUR#	Figure 5-2
CH634W5M CH634W6C CH634W6T	EEPROM default configuration/ GANG_EN=Low level <i>(Note: W7S and X are GANG_EN#=High level)</i>	Independent overcurrent	OVCUR1#, OVCUR2#, OVCUR3#, OVCUR4#	Figure 5-1
CH634W7G CH634W8G CH634X	EEPROM configured as overall overcurrent/ GANG_EN=High level <i>(Note: W7S and X are GANG_EN#=Low level)</i>	Overall overcurrent	OVCUR1#	Figure 5-2
CH634W7R CH634W7S	EEPROM default configuration	Independent overcurrent	OVCUR1#, OVCUR2#, OVCUR3#, OVCUR4#	Figure 5-1
CH634W7U CH634W7V	EEPROM configured as overall overcurrent	Overall overcurrent	OVCUR1# <i>(Note: W7V is OVCUR3#)</i>	Figure 5-2

#### 5.1.2 Power Control

Some CH634 models support 2 power control modes: independent power control mode and overall power control mode, while some models only support overall power control mode, as shown in Table 5-2.

Table 5-2 Power control description

Chip model	Power control configuration	Power control	Power control pin	Reference figure
CH634F	-	Overall control	PWREN#	Figure 5-2
CH634M	-	Overall control	PWREN#	Figure 5-2

CH634W6C	-	Overall control	PWREN#	Figure 5-2
CH634W6G	-	Overall control	PWREN#	Figure 5-2
CH634W5M CH634W6T CH634W7G	EEPROM default configuration/ GANG_EN=Low level <i>(Note: W7S and X are GANG_EN#=High level)</i>	Independent control	PWREN1#, PWREN2#, PWREN3#, PWREN4# <i>(Note: W5M and W6T are high level valid by default)</i>	Figure 5-1
CH634W8G CH634X	EEPROM configure as overall control / GANG_EN=High level <i>(Note: W7S and X are GANG_EN#=Low level)</i>	Overall control	PWREN1# <i>(Note: W5M and W6T are high level valid by default)</i>	Figure 5-2
CH634W7R CH634W7S	EEPROM default configuration	Independent control	PWREN1#, PWREN2#, PWREN3#, PWREN4# <i>(Note: W7V defaults to high level valid)</i>	Figure 5-1
CH634W7U CH634W7V	EEPROM configure as overall control	Overall control	PWREN1# <i>(Note: W7V is PWREN3, defaults to high level valid)</i>	Figure 5-2

### 5.1.3 Independent Overcurrent Detection and Independent Power Control

Figure 5-1 CH634 independent overcurrent detection and independent power supply control

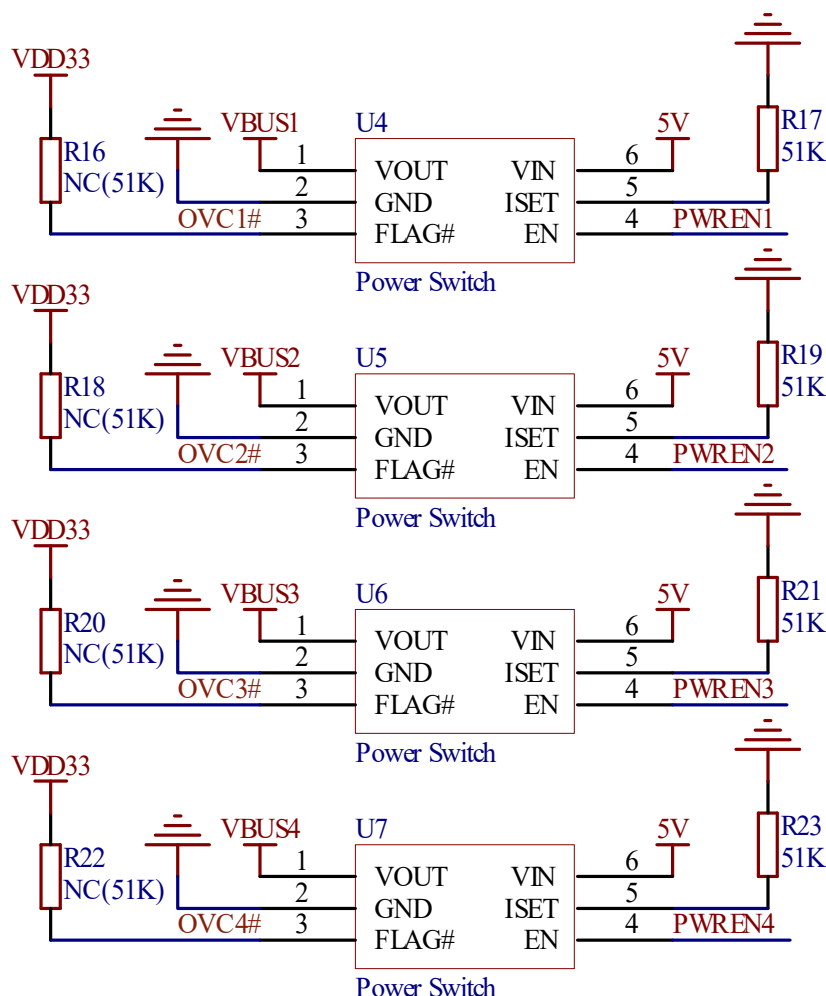

In the above figure, VBUS1-VBUS4 are connected to the VBUS power pins of downstream ports 1-4 respectively. U4~U7 are USB current-limited power distribution switch chips with integrated overcurrent detection for VBUS power distribution management. In applications where 5V is not externally powered, it is recommended to set the current limit to less than 1A through an external resistor connected to ISET. The FLAG pins of U4~U7 are open-drain outputs and need to be pulled up by resistors respectively. The OVCUR# pin of the CH634 chip provides a built-in weak pull-up current, so resistors R16, R18, R20 and R22 can be omitted. The PWRENx# pin of some models of CH634 chips outputs a low level when the power is turned on, and the PWRENx# pin of some models of CH634 chips outputs a high level when the power is turned on (not applicable to the above figure), which can be configured through the PWREN\_POL pin or parameterized through the EEPROM.

### 5.1.4 Overall Overcurrent Detection and Independent Power Control

Figure 5-2 Overall overcurrent detection and overall power control

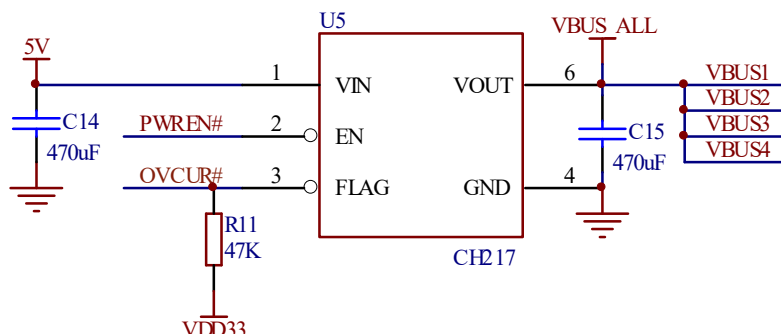

U5 is a USB current-limited power switch chip, such as CH217 chip or similar function chip. R11 can be omitted in the default configuration. The capacity of C14 can be selected as needed. VBUS-ALL is connected to the VBUS power pins of downstream ports 1-4 at the same time. The current limit setting value of U5 needs to take into account the 4 downstream ports and whether it is self-powered.

## 5.2 Reset

The chip has a built-in power-on reset module. Generally, no external reset signal is required. An external reset input pin RESET# is also provided, which has a built-in pull-up resistor.

### 5.2.1 Power-on Reset

When the power is on, the POR power-on reset module inside the chip will generate a power-on reset sequence and delay  $T_{rpor}$  by about 25ms to wait for the power to stabilize. During operation, when the power supply voltage is lower than  $V_{lvr}$ , the LVR low-voltage reset module inside the chip will generate a low-voltage reset until the voltage rises, and delay to wait for the power to stabilize. The following figure shows the power-on reset process and the low-voltage reset process.

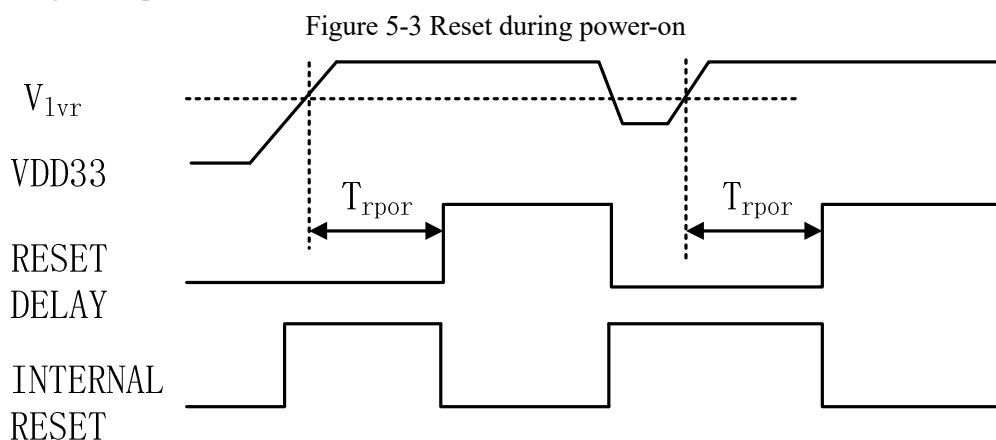

### 5.2.2 External Reset

The external reset input pin RESET# has a built-in pull-up resistor. If the chip needs to be reset externally, the pin can be driven to a low level. The reset low level pulse width needs to be greater than 4 $\mu$ S.

### 5.3 Bus-powered and Self-powered

CH634 supports USB bus power supply mode and self-power supply mode. Bus power supply comes from the USB upstream port, and the power supply capacity is 500mA, 900mA, 1.5A and other standards. The internal resistance loss of the USB cable and the HUB's own consumption will reduce the power supply capacity of the downstream port, and the downstream port voltage may be low. Self-power supply usually comes from an external power port, which depends on the power supply capacity of the external power supply.

Since the voltage of the self-powered and bus-powered devices is not completely equal, the HUB needs to avoid short-circuiting the 2 devices to generate a large current. In addition, when the USB upstream port is powered off, the HUB must also prevent the self-powered external power supply from backflowing current into the USB bus and USB host.

#### 5.3.1 Single 5V Power Supply Solution

The CH634 with VDD5 pin supports a single 5V supply scheme using the built-in LDO and DC-DC. 5V rated input from VDD5 is supplied to the LDO regulator and DC-DC buck, the LDO regulator generates 3.3V to VDD33 which is then connected to AVDD33 and VIO33, and the DC-DC buck generates 1.2V connected to VDD12 and P\*\_VDD12. \_VDD12 and VFB, it is recommended that the 1.2V supply be LC filtered and then supplied to P\*\_VDD12. 3.3V supply has a cumulative capacitance of not less than 10 $\mu$ F to ground, 1.2V supply has a cumulative capacitance of not less than 10 $\mu$ F to ground, it is recommended that the dual 10 $\mu$ F capacitors be connected in parallel, and the ground capacitance of the 5V supply has not been less than 10 $\mu$ F. The 5V supply supports a wider range of voltages, which can be as low as 4V. It is recommended that the 5V power supply be coupled with a 5.5V overvoltage protection device.

Figure 5-4 Schematic diagram of single 5V power supply scheme

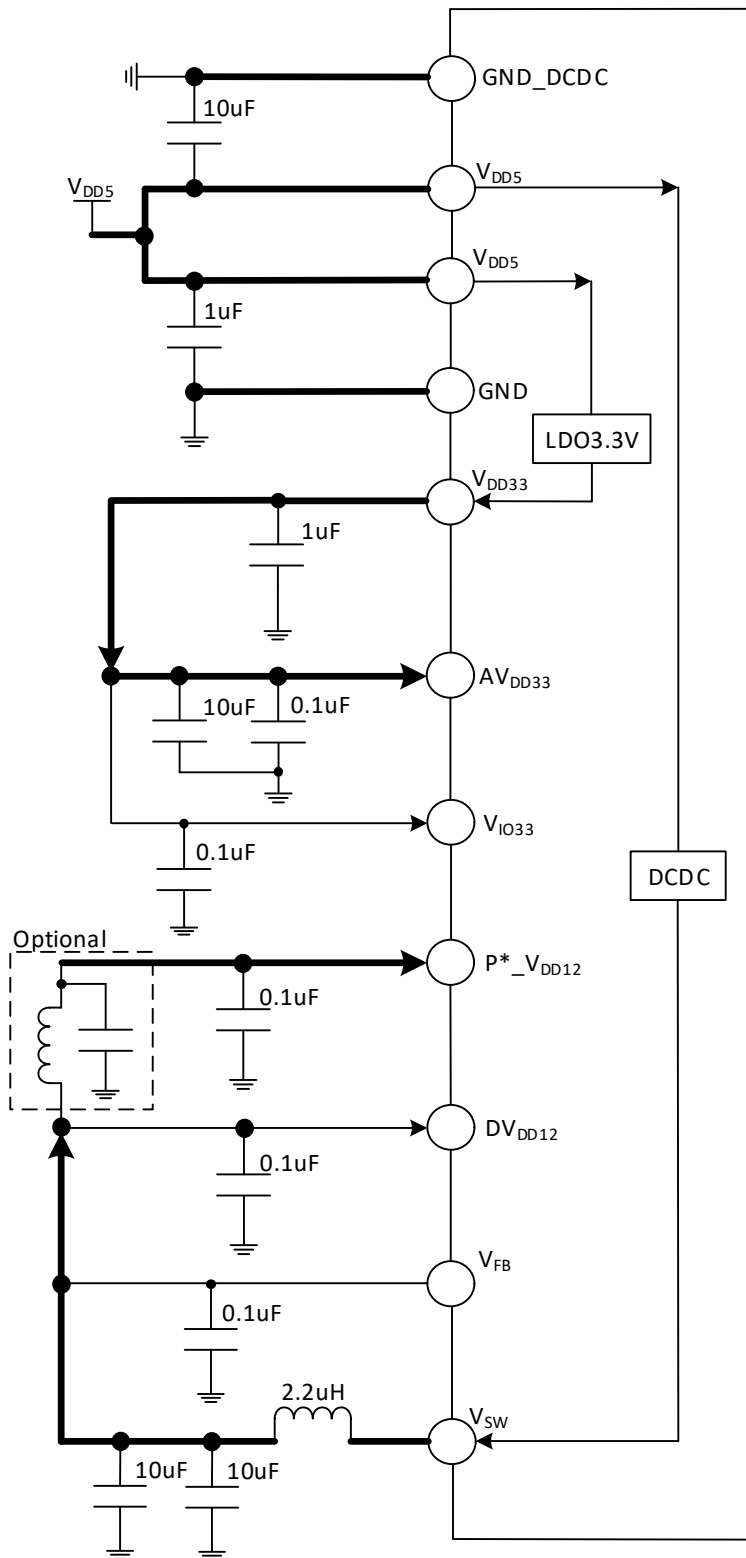

Note: The bolded line in the figure indicates a higher current, and the PCB needs to be designed to ensure sufficient line width and number of vias.

### 5.3.2 Single 3.3V Power Supply Solution

CH634 with VDD5 pin supports a single 3.3V power supply scheme and uses built-in DC-DC. Rated 3.3V is

connected to AVDD33, VIO33 and VDD33. At the same time, rated 3.3V is input from VDD5 and supplied to DC-DC step-down. The DC-DC step-down generates 1.2V which is connected to VDD12, P\*\_VDD12 and VFB. It is recommended that the 1.2V power supply be supplied to P\*\_VDD12 after LC filtering. The cumulative capacitance to ground of 3.3V power supply is not less than 10uF, and the cumulative capacitance to ground of 1.2V power supply is not less than 10uF. It is recommended that double 10uF capacitors be connected in parallel.

Figure 5-5 Schematic diagram of a single 3.3V power supply scheme

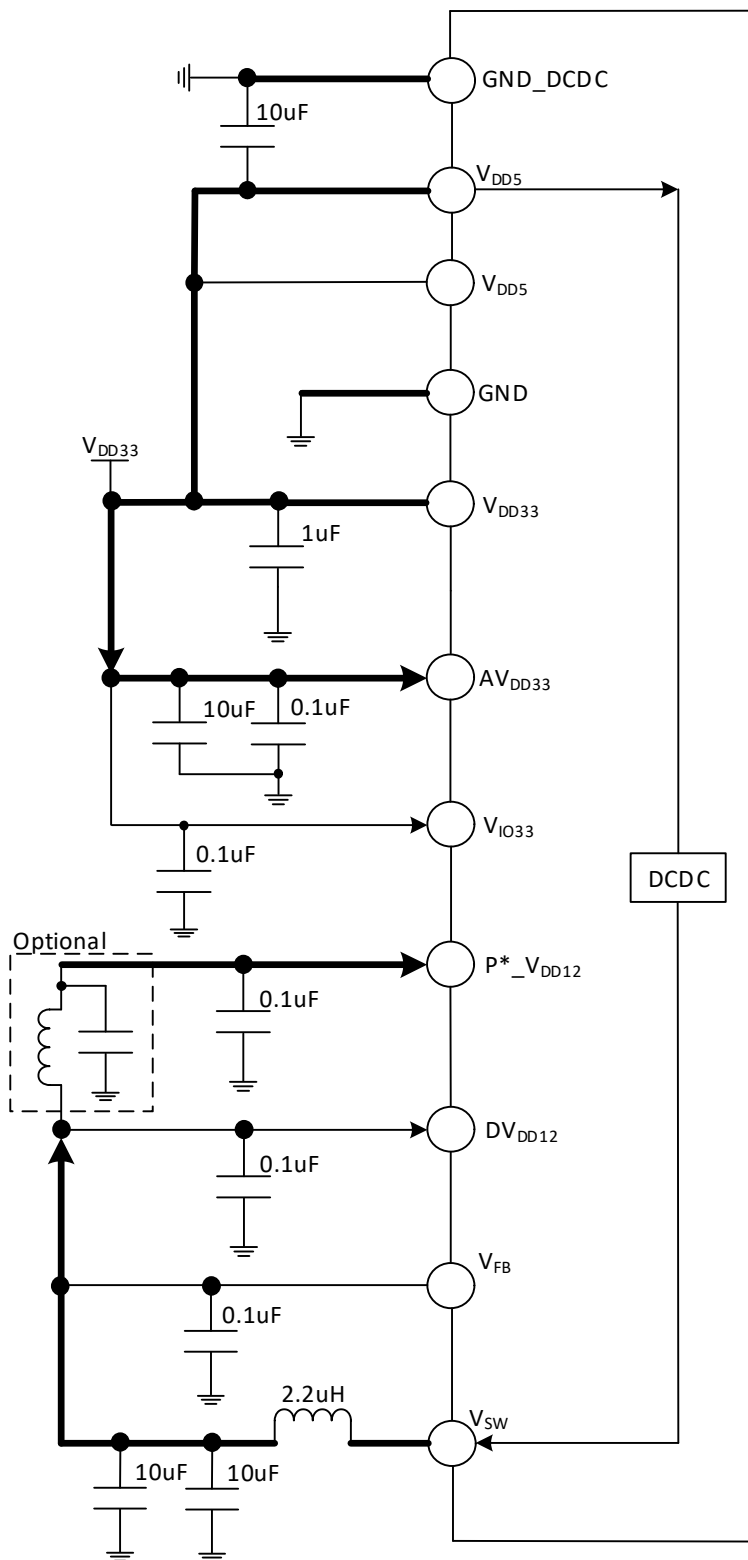



Note: The bolded line in the figure indicates a higher current, and the PCB needs to be designed to ensure sufficient line width and number of vias.

### 5.3.3 3.3V+1.2V Dual Power Supply Solution

CH634 without VDD5 pin only supports 3.3V+1.2V dual power supply scheme. The rated 3.3V is connected to AVDD33 and VIO33, and at the same time, the rated 1.2V (1.23V is recommended, refer to section 6.2) is connected to VDD12 and P\*\_VDD12. The cumulative capacitance to ground of 3.3V power supply is not less than 10uF, and that of 1.2V power supply is not less than 10uF.

If the CH634 with VDD5 pin needs to use external 3.3V+1.2V dual power supply, you can refer to the single 3.3V power supply solution to remove the inductor of the VSW pin, and then supply a rated 1.2V (1.23V is recommended). Because the built-in LDO and DC-DC are not turned off, the static current is slightly large. If you need to turn off the built-in LDO and DC-DC, you can contact the technicians to remove the relevant power connection for the specific model.

## 5.4 LED Indicator

Some models of CH634 chip provide a downstream port status LED indicator control pin. When the green light corresponding to the port is on, it means the port is normal. When the green light is off, it means there is no device on the port or it is suspended. When the red light corresponding to the port is on, it means the port is abnormal.

Figure 5-6 is a schematic diagram of the 8-light mode application of the CH634W7G chip, where LED1-4 are the normal status indicators (green lights) of ports 1-4 respectively. When they are on, it means that a device is plugged into the port and the port is normal. When they are off, it means that there is no device or the port is suspended. LED5-8 are the abnormal status indicators (red lights) of ports 1-4 respectively. When they are on, it means that the port is abnormal, such as overcurrent.

Figure 5-6 Schematic diagram of 8-LED mode application of CH634W7G chip

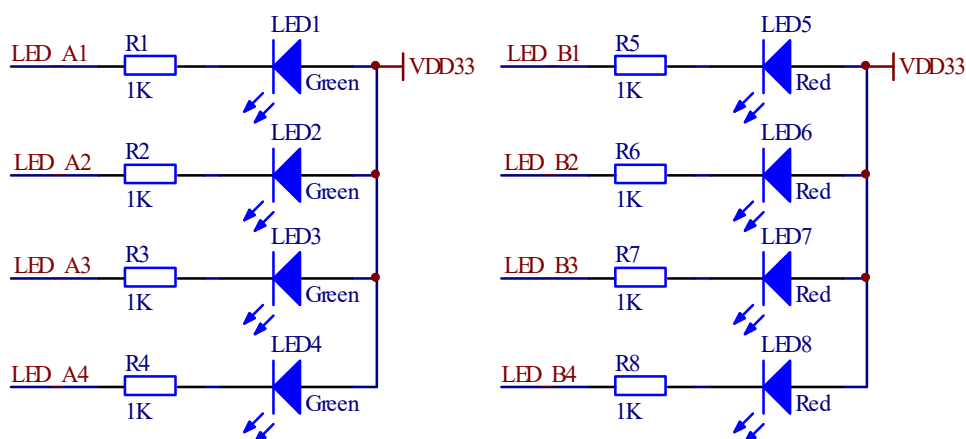

## 5.5 I/O Function Configuration

Some functions of the CH634 chip can be configured in 4 ways: built-in EEPROM, external EEPROM, external SPI interface FLASH and configuration pins. The parameter configuration function of the external EEPROM and

external SPI interface FLASH has a higher priority than the parameter configuration function of the internal EEPROM, and the parameter configuration function of the internal EEPROM has a higher priority than the pin configuration function. Configuration pins are generally multiplexed pins, which are used as configuration pins during reset and switch to corresponding function pins after reset is completed. For specific configuration pins of different models, see the corresponding pin description list.

CH634X chip has 3 C-port operating modes, which can be configured and selected through PDHUB#, SMBDAT and EXCH# pins.

Table 5-3 Configuration of C-port working mode of CH634X chip

C-port operation mode	PDHUB# level	SMBDAT level	EXCH# level	Function description
Mode 0	No pull-down during reset	No pull-down during reset	-	General HUB mode, the upstream port is a type interface, and the downstream port is 2 Type-C interfaces + 2 Type-A interfaces. The Type-C interface supports forward and backward insertion adaptation, and the SMBus interface is turned on.
Mode 1	No pull-down during reset	Low level	Low level	General HUB mode, the upstream port is a Type-C interface, and the downstream port is a Type-C interface + 3 A-type interfaces. The Type-C interface supports forward and backward insertion adaptation. Close the SMBus interface, open the upstream and downstream port exchange, and configure the 45# pin with EXCH# function.
Mode 2	Low level	-	-	In PD-HUB mode, the upstream port is single-sided Type-C interface, which supports the function of Type-C/PD fast charging. It is used in PDHUB, and the downstream port is 1 Type-C interface +3 A-type interfaces, and the Type-C interface supports forward and backward insertion and adaptation. The 45# and 49# pins are configured with SCL function and SDA function respectively, which are used to connect the CH211 chip.

CH634W8G chip also has 3 C-port operating modes, which can be configured and selected through LED\_B4/FUN\_CFG1 and LED\_B3/FUN\_CFG0 pins.

Table 5-4 Configuration of C-port working mode of CH634W8G chip

C-port operation mode	LED_B4/ FUN_CFG1 level	LED_B3/ FUN_CFG0 level	Function description
Mode 0	High level	High level	The upstream port is a type interface, and the downstream

			port is 2 Type-C interfaces+2 Type-A interfaces. The Type-C interface supports forward and backward insertion and adaptation.
Mode 1	High level	Low level	The upstream port is a Type-C interface, and the downstream port is a Type-C interface+3 Type-A interfaces. The Type-C interface supports forward and backward insertion adaptation.
Mode 2	Low level	High level	The upstream port is a single-sided Type-C interface, which supports fast charging of Type-C/PD, and is used for PDHUB. The downstream port is a Type-C interface+3 A-type interfaces, and the Type-C interface supports forward and backward insertion adaptation.

### 5.6 Parameter Configuration Interface

Some models of CH634 provide 2-wire I2C interfaces (SCL and SDA) to communicate with external EEPROM memory chips, and the EEPROM chip address is 0. Some models of CH634 provide communication between 4-wire SPI interfaces (SCS, SCK, MOSI and MISO) and FLASH memory chips with external SPI interfaces. In EEPROM or FLASH, user-defined manufacturer ID, product ID, number of downstream ports, device non-removable characteristics of downstream ports, USB string descriptor and function configuration are stored.

Figure 5-7 Schematic diagram of external EEPROM connection

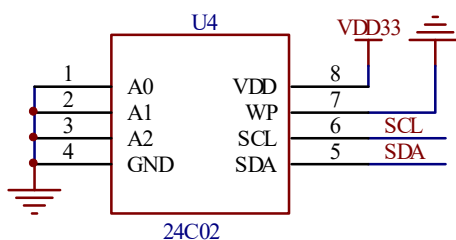
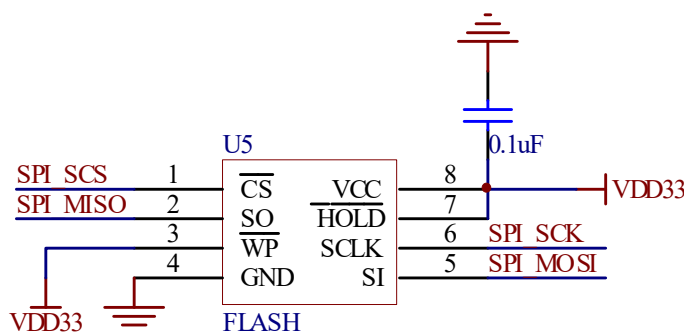

Figure 5-8 Schematic Diagram of External FLASH Connection



CH634 has built-in information memory, which can replace external EEPROM or FLASH to customize manufacturer or product information and configuration in batches according to the special needs of the industry, such as setting the number of downstream ports and setting the equipment non-removable characteristics of downstream ports.

### 5.7 SMBus Configuration Interface

Some models of CH634 provide 2-wire SMBus slave interface to communicate with the external master chip. The SMBus interface contains 2 pins, SMBCLK and SMBDAT, and the communication address is 0x2C, which supports block reading and block writing operations, with a maximum of 32 bytes per block. The external master can read and write EEPROM built in the chip through SMBus interface. Figure 5-9 is the schematic diagram of block reading, and Figure 5-10 is the schematic diagram of block writing.

Figure 5-9 Block reading schematic diagram

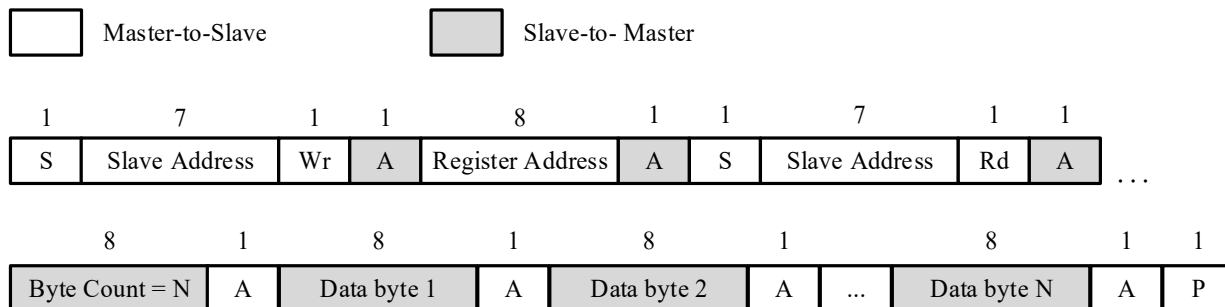
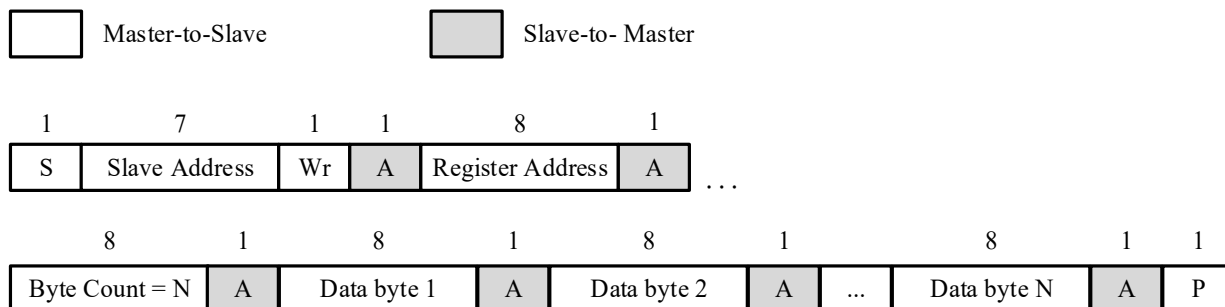

Figure 5-10 Block writing schematic diagram



### 5.8 EEPROM Configuration

CH634 supports loading configuration information such as manufacturer ID VID, product ID PID, USB string descriptor and function configuration from external EEPROM/FLASH or internal EEPROM. If the information in EEPROM is invalid, the default configuration information will be automatically loaded. Table 5-4 describes the specific configuration information of internal/external EEPROM/FLASH. Reserved bytes or reserved bits need to be written according to the original read value during the writing operation.

Table 5-5 Configuration information of internal/external EEPROM/FLASH

Offset address	Parameter abbreviation	Parameter description	Default value
00h	VID_L	Low byte of vendor identification VID.	86h
01h	VID_H	High byte of vendor identification VID.	1Ah
02h	PID_L	The low byte of the product identification code PID is A0h by default. <i>Note: USB2.0 PID is A0h, USB3.0 PID is A1h.</i>	A0h
03h	PID_H	High byte of product identification code PID.	80h
04h	bcdDevice_L	bcdDevice low byte, used to indicate the chip package model;	Follow the model

		Fixed and cannot be modified.	
05h	bcdDevice_H	bcdDevice high byte, used to indicate the chip version; Fixed and cannot be modified.	Follow the model
06h	Fun_Cfg1	Functional configuration byte 1. Bit7: Power supply mode selection; 0: Bus power supply mode (default); 1: Self-powered mode; Bit6: Reserved; Bit5: High-speed mode prohibition control; 0: High-speed mode enabled (default); 1: High-speed mode disabled; Bit4: STT and MTT mode selection; 0: STT mode; 1: MTT mode (default); Bit3: Reserved; Bit2-1: Port overcurrent function control; 00: Overall overcurrent control; 01: Independent overcurrent control; 1x: Overcurrent control is not supported; Bit0: Port power control; 0: Overall power control; 1: Independent power control.	Follow the model
07h	Fun_Cfg2	Functional configuration byte 2. Bit7: Reserved; Bit6: Reserved; Bit5: Reserved; Bit4: Reserved; Bit3: Whether HUB is Compound Device; 0: No; 1: Yes. Bit2-0: Reserved.	20h
08h	Fun_Cfg3	Functional configuration byte 3. Bit7-4: Reserved, the original read value needs to be written when writing; Bit3: Port remapping function control; 0: Disable (default); 1: Enable. Bit2-1: Reserved; Bit0: String descriptor enable control; 0: Disable (default); 1: Enable.	00h
09h	Dev_Removable	Whether the downstream port device can remove the control.	Follow the model

		Bit7-5: Reserved; Bit4-1: Whether the downstream port 4-1 device can be removed; 0: Removable (default); 1: Non-removable; Bit0: Reserved, must be 0.	
0Ah	Port_Dis_Sp	Port prohibition in self-powered mode. Bit7-5: Reserved; Bit4-1: Whether downstream port 4-1 is prohibited; 0: Enable (Default) 1: Disable; Bit0: Reserved, must be 0.	00h
0Bh	Port_Dis_Bp	Port prohibition in bus power supply mode. Bit7-5: Reserved; Bit4-1: Whether downstream port 4-1 is prohibited; 0: Enable (Default) 1: Disable; Bit0: Reserved, must be 0.	00h
0Ch	MaxPwr_Sp	Maximum working current in self-powered mode, in 2mA.	01h
0Dh	MaxPwr_Bp	Maximum working current in bus power supply mode, in 2mA.	32h
0Eh	HubCurrent_Sp	Maximum current required by HUB in self-powered mode.	01h
0Fh	HubCurrent_Bp	Maximum current required by HUB in bus power supply mode.	32h
10h	Pwr_OnTime	Delay time from power-on of downstream port to effective power supply.	32h
11h	LanguageID_H	Language ID high byte.	00h
12h	LanguageID_L	Language ID low byte.	00h
13h	Vendor_StrLen	Manufacturer string descriptor length.	00h
14h	Product_StrLen	Product string descriptor length.	00h
15h	SN_StrLen	Length of serial number string descriptor.	00h
16h-53h	Vendor String	Vendor string descriptor; Vendor string descriptor in Unicode code format.	00h
54h-91h	Product String	Product string descriptor; Product string descriptor in Unicode code format.	00h
92h-CFh	Serial Number String	Serial number string descriptor; Serial number string descriptor in Unicode code format.	00h
D0h	PortNum	Number of downstream ports, valid range: 1-4.	Follow the model

D1h	bcdUSB_L	USB version low byte. bcdUSB_L=0x00, USB2.00; bcdUSB_L=0x01, USB2.01; bcdUSB_L=0x10, USB2.10。	10h
D2h	Fun_Cfg4	Functional configuration byte 4. Bit7-2: Reserved, when writing, you need to write the original read value; Bit1: Forcing the downstream port to be in full speed mode; 0: High-speed mode (default); 1: Full-speed mode; Bit0: LED function enables configuration; 0: Disable (default); 1: Enable.	00h
D3h	Fun_Cfg5	Functional configuration byte 5. Bit7: Polarity configuration of LED indicator; 0: Active low (default); 1: Active high; Bit6: Polarity configuration of port overcurrent detection; 0: Active low (default); 1: Active high; Bit5: Port power control polarity configuration; 0: Active low (Some models default); 1: Active high (Some models default); Bit4: Port BC charge configuration; 0: Disable (default); 1: Enable. Bit3: Whether LPM configuration is enabled; 0: Disable; 1: Enable (default); Bit2: Whether the upstream switching function is enabled; 0: Disable (default); 1: Enable. Bit1-0: Reserved;	Follow the model
D4-E3h	BOS_UUID	UUID field in BOS descriptor, accounting for 16 bytes.	00h
E4-FEh	Reserved	Reserved	00h
FFh	Switch_Ctl	Upstream port switching function control byte; This byte defaults to 00h and is written to a specific value for special control. Bit7: 0: Control byte is invalid, no action is performed;	00h

		<p>1: Control byte is valid, perform control action;</p> <p>Bit6: 0: Cancel exchange (restore non-exchange state);</p> <p>1: Control exchange (original upstream port exchanged for 1# downstream port, original 1# downstream port exchanged for upstream port);</p> <p>Bit5: 0: Execute control action only without saving;</p> <p>1: Execute control action and power-down save;</p> <p>Bit4: 0: Enable original downstream port (1# downstream port) U3 function;</p> <p>1: Disable the original downstream port (1# downstream port) U3 function;</p> <p>Bit3: 0: Enable original downstream port (1# downstream port) U2 function;</p> <p>1: Disable original downstream port (1# downstream port) U2 function;</p> <p>Bit2: Reserved;</p> <p>Bit1: 0: New downstream port (original upstream port) U3 function normal after exchange;</p> <p>1: New downstream port (original upstream port) U3 function after exchange is disabled;</p> <p>Bit0: 0: New downstream port (former upstream port) U2 function normal after exchange;</p> <p>1: New downstream port (former upstream port) U2 function disabled after exchange;</p> <p>For example:</p> <p>(1) Write C0h to indicate control exchange, the new downstream port (original upstream port) U3 function is normal and U2 function is normal after exchange;</p> <p>(2) Write C1h to indicate control exchange, the new downstream port (original upstream port) U3 function is normal and U2 function is disabled after exchange;</p> <p>(3) Write 80h to cancel the exchange and return to the non-exchange state;</p> <p>(4) Write 98h to cancel the exchange and disable the U3 and U2 functions of the original downstream port (1# downstream port).</p>	
--	--	---	--



## 6. Parameters

### 6.1 Absolute Maximum

(Critical or exceeding the absolute maximum value may cause the chip to operate improperly or even be damaged.)

Name	Parameter description	Min.	Max.	Unit
$T_A$	Ambient temperature at work	-40	85	°C
$T_J$	Junction temperature range	-40	100	°C
$T_S$	Ambient temperature during storage	-55	150	°C
$V_{DD5}$	Input supply voltage of LDO voltage regulator and DC-DC buck ( $V_{DD5}$ )	-0.4	5.5	V
* $V_{DD33}$	Operating power supply voltage ( $V_{DD33}/AV_{DD33}$ )	-0.4	4.0	V
$V_{IO33}$	I/O supply voltage ( $V_{IO33}$ )	-0.4	4.0	V
* $V_{DD12}$	USB module power supply voltage ( $P*_V_{DD12}$ )/ core power supply voltage ( $DV_{DD12}$ )	-0.4	1.5	V
$V_{FB}$	DCDC voltage feedback terminal	-0.4	1.5	V
$V_{USB2}$	Voltage on USB2.0 physical signal pin	-0.4	$V_{DD33}+0.4$	V
$V_{USB3}$	Voltage on USB3.0 physical signal pin	-0.4	$V_{DD12}+0.4$	V
$V_{IN}$	Input voltage on FT (tolerant 5V) pin.	-0.4	5.5	V
	Input voltage on other pins	-0.4	$V_{IO33}+0.4$	V
$V_{ESD(HBM)}$	ESD electrostatic discharge voltage (HBM) of common I/O pin.	4K		V

### 6.2 Electrical Parameters (Test condition: $T_A = 25^\circ\text{C}$ , \* $V_{DD33} = V_{IO33} = 3.3\text{V}$ , \* $V_{DD12} = 1.2\text{V}$ )

Name	Parameter description	Min.	Typ.	Max.	Unit
$V_{DD5}$	Input power supply voltage of LDO regulator and DCDC buck	4.0	5.0	5.25	V
* $V_{DD33}$	Operating power supply voltage of single 3.3V power supply scheme or chip package without $V_{DD5}$ pin.	3.2	3.3	3.4	V
	Operating voltage under single 5V power supply scheme (LDO regulator output)	3.2	3.3	3.4	V
* $V_{DD12}$	USB module power supply voltage ( $P*_V_{DD12}$ )/ core power supply voltage ( $DV_{DD12}$ )	1.18	1.23 <sup>(1)</sup>	1.3	V
$V_{IO33}$	I/O pin supply voltage	3.0	3.3	3.6	V
$I_{SLP}$	Deep sleep power supply current (excluding 1.5K $\Omega$ pull-up)		1.7		mA
$V_{IL}$	Low level input voltage	Standard I/O pin	0	0.8	V
		FT I/O pin	0	0.8	V
$V_{IH}$	High level input voltage	2.0		$V_{IO33}$	V

		FT I/O pin	2.0		5.0	V
V <sub>OL</sub>	Low level output voltage	Sink current 5mA		0.4	0.6	V
V <sub>OH</sub>	High level output voltage	Source current 5mA	V <sub>IO33</sub> -0.6	V <sub>IO33</sub> -0.4		V
R <sub>PU</sub>	Pull-up equivalent resistance			70		KΩ
R <sub>PD</sub>	Pull-down equivalent resistance			70		KΩ

Note: 1.\* VDD12 current is large, considering the PCB alignment voltage drop loss, it is recommended to rated 1.2V plus 20~60mV.

### 6.3 Typical Working Current (Test condition: CH634W8G, T<sub>A</sub> = 25°C)

Number of downstream connection devices		Single 5V power supply scheme	3.3V+1.2V dual power supply scheme		Unit
		5V power supply	3.3V power supply	1.2V power supply	
USB3.0	Sleep mode	0.50	0.28	0.30	mA
	Suspension	1.9	1.5	1.2	mA
	1	88.1	19.6	234	mA
	2	114	19.6	308	mA
	3	141	19.6	380	mA
	4	170	19.6	450	mA
USB2.0	Sleep mode	0.50	0.28	0.30	mA
	Suspension	0.90	0.82	1.2	mA
	1	46	41	17	mA
	2	59	55	17.1	mA
	3	73	71	17.3	mA
	4	97	84	17.5	mA

Note: A single 5V power supply scheme only consumes current from 5V; While the 3.3V+1.2V dual power supply scheme consumes current from 3.3V and 1.2V respectively.

## 7. Package Information

Note: All dimensions are in millimeters.

The pin center spacing values are nominal, without error. And the error of dimensions other than the pin center spacing values is not more than  $\pm 0.2\text{mm}$ .

### 7.1 QFN32

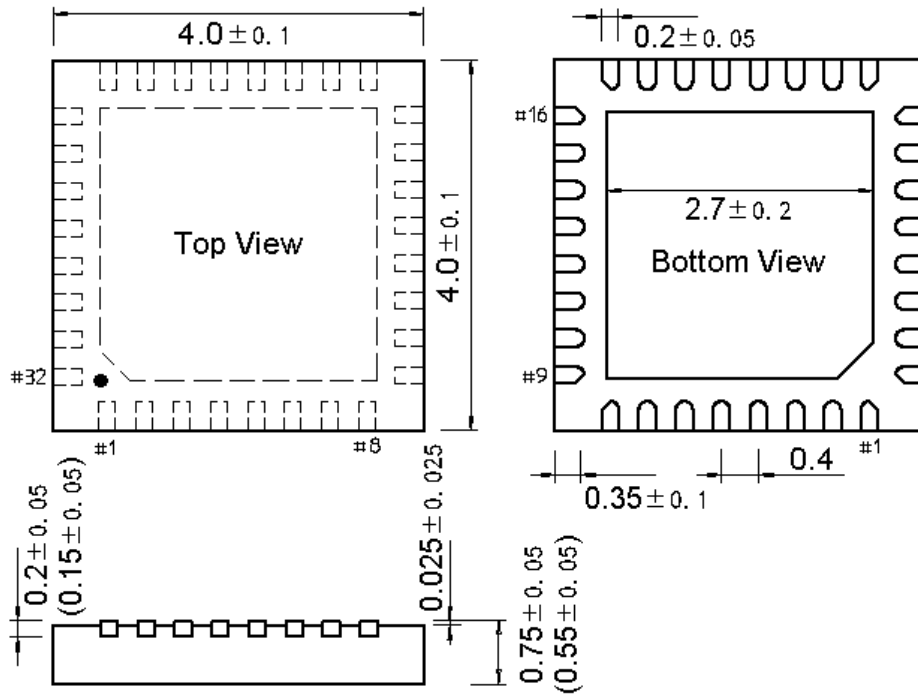

7.2 QFN48

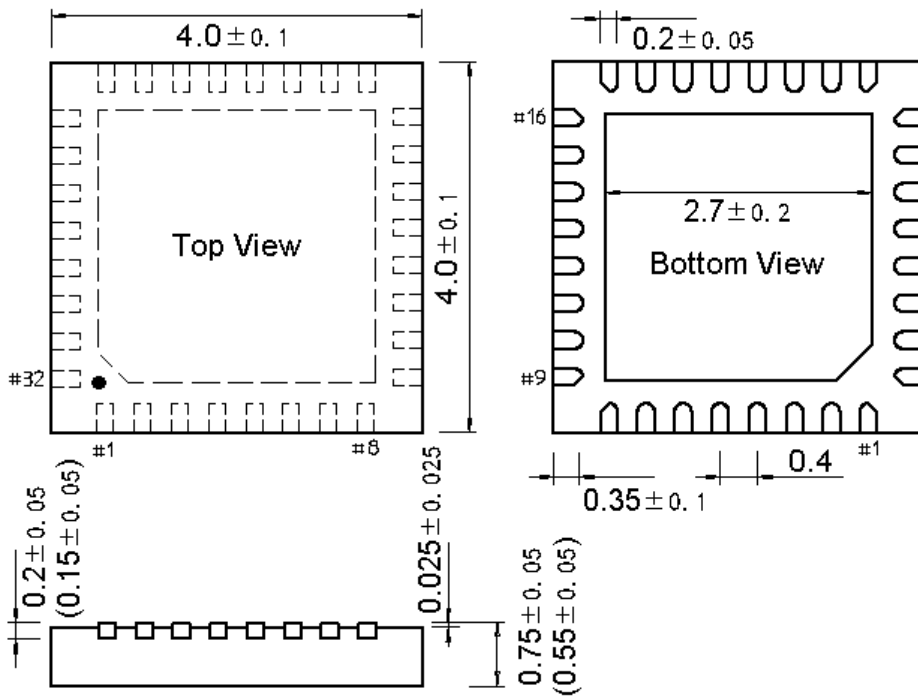

7.3 QFN64

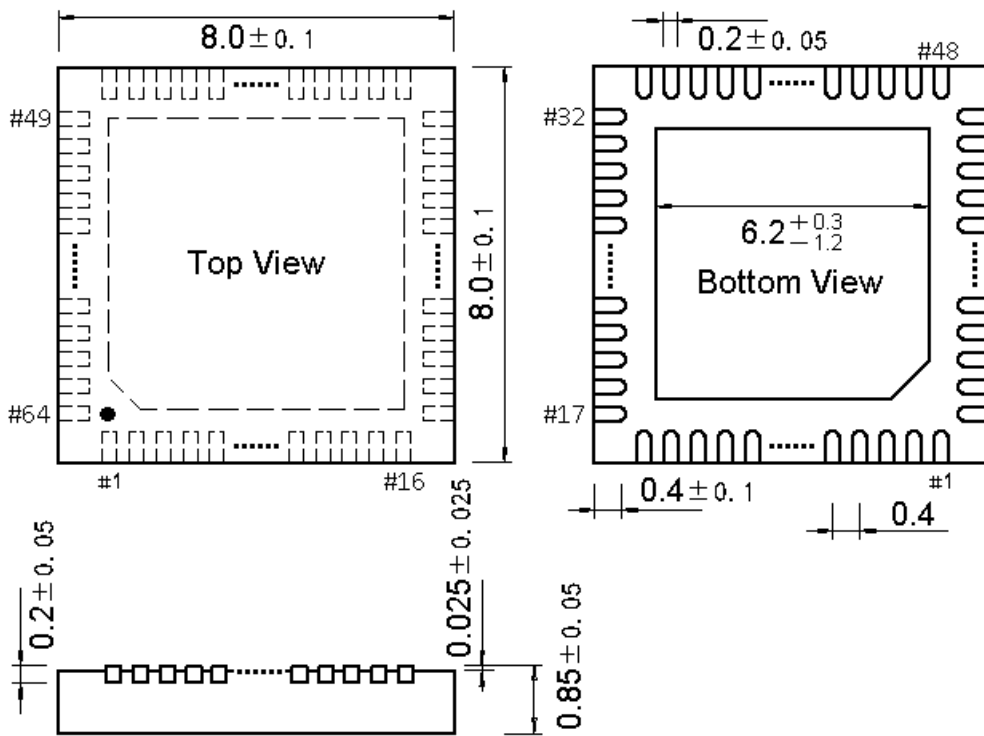

7.4 QFN68

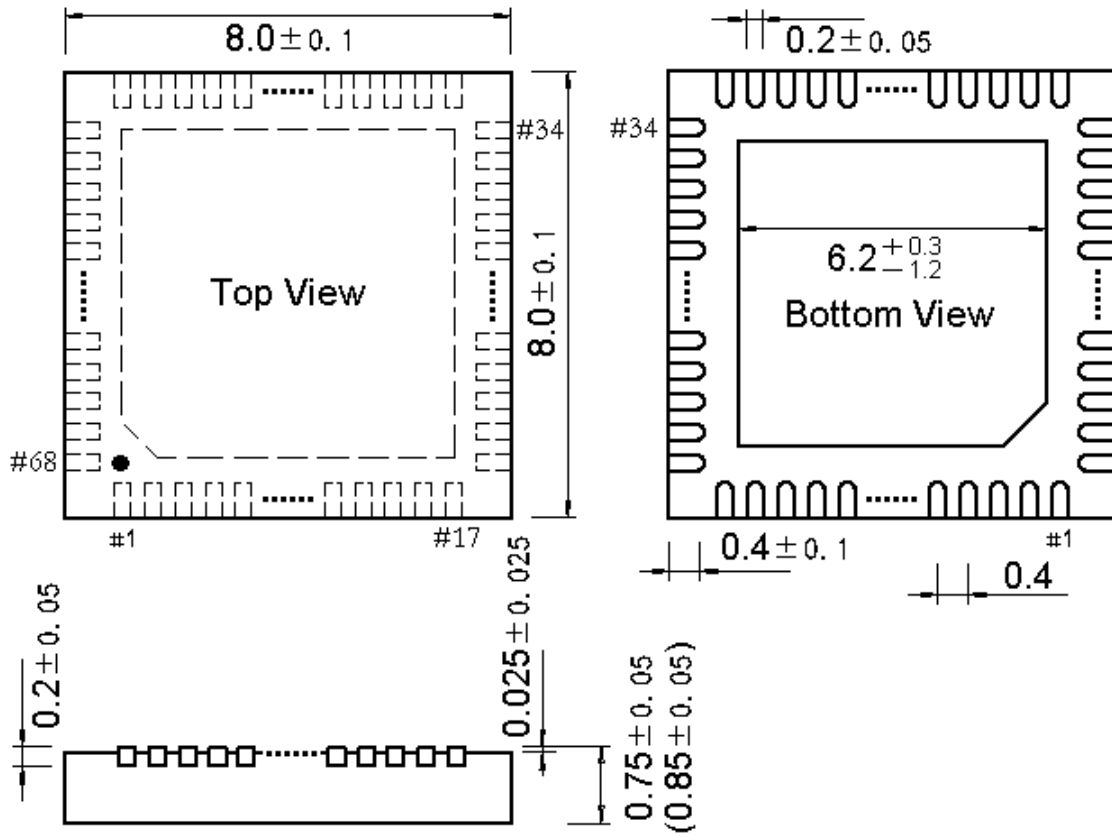

## 8. Applications

### 8.1 Dual Type-C Forward and Backward Insertion Adaptive Downstream Port Application

Figure 8-1 below shows the reference circuit diagram of CH634X chip working in mode 0. P1-P4 are the four downstream USB ports of the HUB, among which P1 and P2 are Type-C interfaces, which are compatible with USB-C cables and connection specifications, and native support for Type-C forward and backward insertion adaptation; P3 and P4 are Type-A interfaces, P5 is the upstream USB port of the HUB, generally connected to a PC or other HUB host, and P6 is the external power supply Type-C interface.

U3 is an ideal diode CH213 with low voltage drop, which has simple over-current and short-circuit protection functions and faster protection response, and can replace Fuse. It is mainly used to avoid backflow of external power supply of P6 to VDD5 of upstream port P5, especially when the upstream port, such as computer, is turned off and the external power supply of P6 is still available. Theoretically, U3 can be replaced by Schottky diode, but it is necessary to choose a device with low voltage drop, otherwise it will reduce the output voltage of the downstream port VBUS. At a load current of 300mA, the voltage drop of Schottky diode is about 0.3V, and the voltage drop of ideal diode is about 0.05V. Because P6 itself and external power supply usually have no load, the backward flow from P5 to P6 is generally not considered.

CH634X chip works in independent power distribution control and independent overcurrent detection mode by default, and can be configured into overall power distribution control and overall overcurrent detection through OVCUR3#/GANG\_EN# pin and OVCUR4#/GANG\_EN# pin. U4-U7 is a USB distribution switch chip CH217 that supports overcurrent protection. In the figure, R17, R19, R22 and R25 set current limiting thresholds according to the power supply capacity, and the FLAG# pin of the USB current-limiting power switch chip can generate over-current or over-temperature alarm signals to inform the HUB controller and computer, and the OVCUR# pin of CH634X has built-in pull-up resistors.

P1 and P2 ports of CH634X chip can also be used as type-A interfaces. If the USB3.0 signal line uses PxC\_SS\_RXA, PxC\_SS\_RXB, PxC\_SS\_TXA and PxC\_SS\_TXB, the Px\_CC2 pin needs to be grounded through a 5.1K resistor; If the USB3.0 signal line uses Px\_SS\_RXA, Px\_SS\_RXB, Px\_SS\_TXA and Px\_SS\_TXB, the Px\_CC1 pin needs to be grounded through a 5.1K resistor.

When designing PCB, the actual working current carrying capacity should be considered. The PCB of GND routing paths of VDD5, VBUS\_OUT\*, 5V and P6 of each port should be as wide as possible. If there are vias, it is recommended to connect them in parallel.

At the instant when the USB device in the downstream port is hot-plugged, the dynamic load may cause the voltage of VBUS and 5V to drop instantly, which may lead to the low-voltage reset of LVR, thus causing the phenomenon that the whole HUB is disconnected and reconnected. Improvement methods: ① Increase the electrolytic capacitance of 5V power supply (increase C14 capacity as shown in the figure) within the scope permitted by the specification to alleviate the drop; ② Increase the capacitance of the power input terminal of the HUB chip (increase the capacity of C37 as shown in the figure, for example, 22uf); ③ Enhance the 5V power supply capacity or change to self-power supply. In addition, improving the quality of USB wire will also improve the power supply capacity.

It is recommended to add 5V overvoltage protection devices, and all USB signals should be added with ESD protection devices, such as CH412K, whose VCC should be connected to 3.3V.

Figure 8-1 CH634X Chip reference circuit diagram

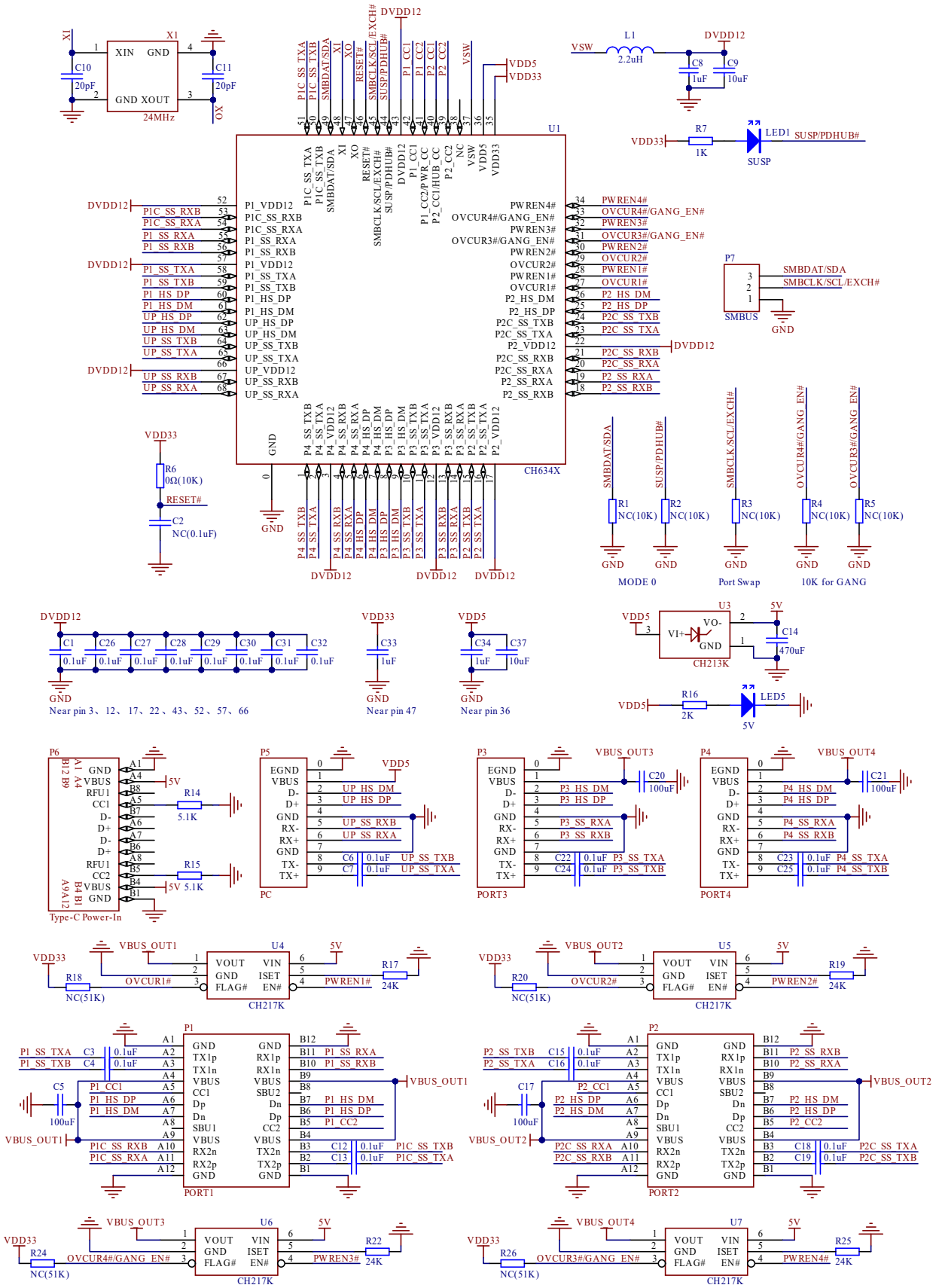

## 8.2 Type-C/PDHUB 100W Fast Charging Application

Figure 8-2 below shows the reference circuit diagram of CH634W6G working in PDHUB mode. The PD protocol is implemented by CH634W6G, and it natively supports USB PD2.0/3.0 protocol, which can charge the maximum power of 100W (20V\*5A) while communicating with USB HUB on Type-C interface. CH211 is a Type-C/PD high-voltage interface chip with built-in high-voltage switch and boost module, which provides high-voltage drive with CH634W6G and supports low-cost N-type MOSFET power switch.

P1-P4 are the 4 downstream USB ports of the HUB, P5 is the upstream USB port of the HUB, which is generally connected to a PC or other HUB host, and P6 is a pure power supply Type-C interface, which is only used for connecting external power adapters. The P5 port is a single-sided Type-C interface, which supports the angle color DRP switching of Type-C power supply. If P6 is connected to an external power adapter, P5 port will work in SRC/DFP mode, and the PDHUB will transmit the external power source to PC for charging, and at the same time supply it to DC-DC to generate 5V VBUS power for USB. If only PC is connected and P6 port has no power supply, P5 port works in SINK/UFP mode, and the PDHUB applies for power supply from PC to DC-DC.

DC-DC will step down the maximum voltage of VHV from 20V to 5V. The DC-DC controller should support full duty cycle output, and the continuous output current should not be less than the actual demand of 4 downstream ports, and it is recommended that it should not be less than 3A. The internal resistance of MOSFET is recommended not to exceed 16mΩ, so as to reduce the heating when the charging current lasts for 5A. If only 5V\*3A is needed, DC-DC can be omitted and the withstand voltage of MOSFET can be reduced.

R12 is used to prohibit BC from charging. If R12 is removed, BC charging is enabled, and LED1 replaces LED3.

If you need to support fast charging with 28V voltage, 140W power or other specific voltage/power, or bidirectional fast charging, or provide PD high-power fast charging for the downstream Type-C port, please contact our company.



Figure 8-2 CH634W6G Chip reference circuit diagram

